

# Requirements for Design, Construction, and Maintenance of Customer Owned Sewer & Water Services & Appurtenances

## Ordinance Attachment: Technical Specifications



NTPUD COMPLIANCE DIVISION

5/22/2024



REQUIREMENTS FOR DESIGN, CONSTRUCTION, AND MAINTENANCE OF CUSTOMER OWNED  
SEWER & WATER SERVICES & APPURTENANCES

Table of Contents

Table of Contents .....1

1 GENERAL CONDITIONS.....2

2 GRAVITY SEWER SERVICE.....6

3 WASTE PRETREATMENT REMOVAL DEVICES .....13

4 INDIVIDUAL SEWER PUMP STATIONS.....15

5 DOMESTIC WATER SERVICE .....18

6 FIRE SERVICE .....24

7 BACKFLOW AND CROSS-CONNECTION CONTROL .....26

Figures

2.1: Sewer Gravity Service ..... 8

2.2: Sewer Cleanout..... 9

2.3: Water-Sewer Service Common Trench Separation..... 10

2.4: Excavation Space Requirements for Water-Sewer Taps or Abandonment..... 11

4.1: Pumped Sewer Systems..... 16

4.2: Pressurized Sewer Service..... 17

5.1: Domestic Water Service ..... 20

5.2: Future Water Service..... 21

5.3: Water-Sewer Service Common Trench Separation..... 22

5.4: Excavation Space Requirements for Water-Sewer Taps or Abandonment..... 23

6.1: Fire Service..... 25

REQUIREMENTS FOR DESIGN, CONSTRUCTION, AND MAINTENANCE OF CUSTOMER OWNED  
SEWER & WATER SERVICES & APPURTENANCES

## 1 GENERAL CONDITIONS

- 1.01 District Authority:** Authority is granted to North Tahoe Public Utility District (NTPUD or District) through:
- A. **North Tahoe Public Utility District:**
- **Sewer:** Sewer Ordinance
  - **Water:** Water Ordinance
- B. **State of California:** Public Utilities Code, Sections 16461 - 16489
- **Sewer:** Order No. WQ 2006-0003-DWQ – Statewide General Waste Discharge Requirements for Sanitary Sewer Systems.
  - **Water:** Title 17 Code of Regulations
- 1.02 District Jurisdiction:** These requirements are applicable within the jurisdictional boundaries of NTPUD for the construction of water and sewer service lines and/or associated appurtenances within private properties and/or within public Right-of-Way as required to serve a property, or properties, and to fully comply with District Ordinances.
- 1.03 Ownership Threshold:** All Sewer and Water infrastructure and appurtenances within private property limits shall be constructed, owned, and maintained by the property owner in accordance with District Ordinances and these Technical Specifications, except for District owned mains (lines serving more than one service) and/or facilities within District Easement(s).
- 1.04 Codes:** Construction of sewer and/or water service lines and/or associated appurtenances shall be in accordance with:
- A. California Plumbing Code (Latest edition) [CPC]
- B. NTPUD Ordinances (Latest edition as passed by the NTPUD Board of Directors)
- 1.05 State Code References:** Any/all requirements noted herein with reference to State codes are provided only for the benefit of the customer as a clean, compiled, and condensed source of information. In all cases the full requirements of State Code(s) shall apply and shall be the owner/contractor’s obligation to comply.
- 1.06 Abbreviations:**
- |   |  |
|---|--|
| A. AWG: American Wire Gauge               | F. DR: Dimension Ratio                   |
| B. AWWA: American Water Works Association | G. HDPE: High Density Polyethylene       |
| C. CPC: California Plumbing Code          | H. IPS: Iron Pipe Size                   |
| D. CRC: California Residential Code       | I. psi: pounds per square inch           |
| E. DI: Ductile Iron                       | J. PVC: Polyvinyl Chloride               |
|   | K. SIDR: Standard Inside Dimension Ratio |
- 1.07 District Plan Review and Approval:** District shall review and approve plans for any/all new construction, additions, remodels, and/or demolition. District review will be limited to Sewer and/or Water aspects and/or elements. Plans are reviewed and approved in accordance with District plan review process.
- 1.08 County and Fire District Approval:** Property improvements require County and Fire District approval as applicable per these agencies. The applicant is advised to contact Placer County Building Department to determine level of review/approval required.
- 1.09 Payment of District Connection Fees:** Customer shall pay all applicable fees upon approval of plans for construction, rebuilding, remodeling, inspection of service lines, and/or installation of sewer and/or water

**REQUIREMENTS FOR DESIGN, CONSTRUCTION, AND MAINTENANCE OF CUSTOMER OWNED  
SEWER & WATER SERVICES & APPURTENANCES**

services. Connection and installation fees shall be based on size(s) and/or customer class(s) of each individual service use as applicable. See Sewer and Water Ordinance Attachments A-2 and A-3.

- A. **Accessory Dwelling Units (ADU):** Secondary living unit on same parcel as determined by Placer County. District will coordinate directly with Placer County to confirm this determination. If secondary unit is determined by Placer County to be an ADU, see below if said unit qualifies as an Exempt ADU. ADU constructed with new single-family home does not qualify as Exempt ADU. Unless an ADU qualifies as an Exempt ADU, regular connection and similar fees will be imposed. These fees are proportional to the burden of an ADU.
- B. **Exempt ADU:** An Exempt ADU shall be exempt from payment of District Connection Fees owed. There shall only be one Exempt ADU per parcel. Exempt ADU definition:
  - (1) Located within a zone for single-family use
  - (2) Contained within the existing space of a single-family residence or accessory structure (including, but not limited to, a studio, pool house, or other similar structure) and may include an expansion of not more than 150 square feet beyond the same physical dimensions as the existing accessory structure. Expansion beyond the physical dimensions of the existing accessory structure shall be limited to accommodating ingress and egress only.
  - (3) Has independent exterior access from the existing residence
  - (4) The side and rear setbacks are sufficient for fire safety

**1.10 Service Line Size(s):** Determined during District Plan review process.

- A. **Water:** Customer Service line and Meter Size: As Required per District Plan review and CPC Tables 610.3 and 610.4. ¾" minimum.
- B. **Sewer:** Private Service Lateral (Pipe) (a.k.a. Upper Lateral) Size: As Required per District Plan review and CPC Tables 703.2 and 717.1 as applicable. Drainage fixture units as determined per Table below. Single Family Residential: 4" minimum. All Other customer classes: 6" minimum.

<b>Drainage Fixture Units</b>	
<b>Description</b>	<b>Fixture Units</b>
Bathtub or combination bath/shower	2
Clothes washer, domestic	3
Dental unit, cuspidor	1
Dishwasher, domestic, independent drain	2
Drinking fountain (each head)	0.5
Food waste disposer, commercial	3
Floor drains, emergency	0
Floor drains ( each)	2
Shower, single-head trap	2
Multi-head, each additional	1
Lavatory	1
Lavatory in sets	2
Sink (bar)	2
Sink (commercial with food waste)	3
Sink (exam room)	1
Sink (domestic, with or w/out food waste disposer, dishwasher, or both)	2
Sink (laundry)	2
Sink (service or mop basin)	3
Sink (washup, flushing rim)	6
Sink (washup, each set faucets)	2
Urinal	2
Toilet (1.6 gpf, any type)	4
Toilet (>1.6 gpf, any type)	6

REQUIREMENTS FOR DESIGN, CONSTRUCTION, AND MAINTENANCE OF CUSTOMER OWNED  
SEWER & WATER SERVICES & APPURTENANCES

- 1.11 District Inspections:** No backfilling shall be performed until the District has inspected and approved the installation for covering. The Customer (or Customer's representative, Contractor, etc.) shall schedule all inspections at least three (3) business days in advance. All testing shall be performed in the presence of a representative of the District.
- 1.12 Inspection Fees:** Inspection fees, per Ordinance attachment A-3, shall be charged for each inspection, each re-inspection (if the initial inspection fails), and/or if the site is not ready for inspection.
- 1.13 District Infrastructure Locations:** The District will provide approximate location(s) and size(s) of all District owned utilities, including existing sewer stubs originally placed intended to serve a parcel. Locations are provided based on all best available information in District files. No guarantees are made regarding the accuracy of locations provided. It is the property owner's, and/or their agents, responsibility to accurately field locate to establish actual location(s) required for connection to system. All work in County and/or State Right-of-Way (ROW) requires approval from Placer County and/or Caltrans prior to execution.
- 1.14 Service Connections (Sewer and/or Water):** District owned service line from District main to service connection at property line shall consist of a single/separate line, per parcel served, sized as required to serve all use/demand on property as anticipated at time of installation (unless otherwise approved). If new District owned service line is required, customer shall obtain County/State permit, excavate trench, backfill and restore surface as required per District and County/State permits. District beds trench, lays service line, and pipe zone backfills. Applies to both sewer and water service. Sewer and water service connection shall comply with one of the following, whichever is applicable:
- A. **Single Family Residence:** Where a single-family residence is constructed on a single parcel, direct separate connection to the District's sewer and water system shall be made. Connection shall be made at the property line, except locations where connection to District infrastructure located in District owned easements applies.
  - B. **Multiple Family Residence (single owner):** Where a multiple-family residence (single owner) is constructed on a single parcel, direct separate connection to the District's sewer and water system shall be made. Connection shall be made at the property line, except locations where connection to District infrastructure located in District owned easements applies.
  - C. **Multiple Residences (independently owned) with Common Area Land Ownership / Commercial Developments:** A development with multiple separately owned structures and/or units, surrounded by common land ownership (i.e. Homeowners Association, Common Interest Development) , shall be served by said common ownership sewer and water system directly connected to the District's sewer and water system as applicable. Connection to District's system shall be made at the common property line (public right-of-way/private development), except locations where connection to the District infrastructure is located in District easements. The District shall review and approve proposed sewer and water design, and dictate the number, location, and size of the meter(s). The District reserves the right to meter as it sees fit for the benefit of the general public. If the development is master metered (preferred), sub-metering of water services is required [CPC 601.2.1]. The operation and maintenance of the common owned sewer and water system (including sub-meters) shall be the responsibility of the owner(s) of the common ownership having legal responsibility for the development.
  - D. **Multiple Residences (independently owned) without Common Area Land Ownership / Commercial Developments:** A development with multiple separately owned structures and/or units, mapped without common land ownership (i.e. Homeowners Association, Common Interest Development) (and instead mapped with easement rights across other private parcels shall be separately served for each separately owned parcel, structure, or unit directly connecting to the District's sewer and water system. Connection to the District's system shall be made at the private property/County or State Right-of-Way

## REQUIREMENTS FOR DESIGN, CONSTRUCTION, AND MAINTENANCE OF CUSTOMER OWNED SEWER & WATER SERVICES & APPURTENANCES

line, except locations where connection to District infrastructure located in District easements applies. The District will not own or maintain infrastructure on private party, unless currently existing. Private easements for private utilities to/from adjacent landowners are required as applicable per final parcel layout and service locations. The District shall review and approve proposed sewer and water design, and dictate the location, and size of the meter(s). The operation and maintenance of the privately-owned sewer and water system shall be the responsibility of the owner of parcel obtaining District service.

- 1.15 Private Easements and/or Extensions:** Should the parcel not border upon public right-of-way or easement containing the District's utilities, it is the property owner's responsibility to obtain necessary easements and/or construct main extensions as deemed necessary by the District. All main extensions shall be performed in accordance with District Ordinances.

## HELPFUL HINTS FOR CUSTOMERS

- CALL BEFORE YOU DIG – Call USA North (Underground Service Alert) at 811/800-227-2600 at least two (2) business days before any type of proposed excavation is to take place. This is a free service, could save you thousands of dollars in repair costs, and IT'S THE LAW.
- Obtain an Encroachment Permit from County or Caltrans if excavating is proposed in County or State Right-of-Way. Contact the District for reference to the applicable County or State department.
- See Sewer/Water Ordinance Attachment 3 for applicable charges for District Services.
- Call the District a minimum of three (3) business days in advance for scheduling of District services:
  - Sewer/Water Tapping
  - Sewer/Water Trench Inspections
  - Sewer Pressure Test
  - Water Meter Installations
  - Water Reconnections
  - Etc.
- For common trenching (joint sewer/water service trench), request both inspections at same time.
- Water meter installation must be scheduled and completed prior to water lateral testing and inspection. Excavations must be completed, clear of debris, and ready for meter installation.



REQUIREMENTS FOR DESIGN, CONSTRUCTION, AND MAINTENANCE OF CUSTOMER OWNED  
SEWER & WATER SERVICES & APPURTENANCES

## 2 GRAVITY SEWER SERVICE

- 2.01 General:** Where practical, plumbing fixtures shall be drained to the public sewer system by gravity. [ref: CPC 709.1]
- 2.02 Private Service Lateral (Pipe) (a.k.a. Upper Lateral) Size:** As shown on Plans. See Section 1.07 "District Plan Review and Approval" and Section 1.10 "Service Line Size(s)".
- 2.03 Location:** Trenches deeper than the footing of a building or structure, and paralleling the same, shall be located not less than 45 degrees from the bottom of the exterior edge of the footing. [ref: CPC 314.1]
- 2.04 Customer Lateral Materials and Depth/Cover:** Per Table below. No other pipe type allowed.

Customer Lateral				
Pipe		Minimum Cover		Maximum Cover
Type	Class	Non-traffic	Traffic	
PVC	SDR 35	30"	48"	12'
PVC	C900 DR 14	24"	30"	n/a
DI	CL 51 or greater	24"	24"	n/a

Note: Less than 24" not allowed [ref: CPC 312.6 freeze protection. note: local frost depth = 24" per Placer Co. foundation depth requirements (ref: CRC R403.1.4.1 and County "Foundation and Slab Inspections Checklist")]

- 2.05 Coupling and Joining:** Generally, pipe to pipe will be coupled via pipes gasketed bell and spigot. When independent couplings are necessary, coupling shall be MaxAdaptor or approved equal. Couplings shall be specifically designed for proposed installation. Glued joints are not permitted.

Rigid couplings shall be MaxAdaptor, or other approved.

Where different pipe materials/sizes are being coupled, couplings other than those listed above shall be approved by the District.

- 2.06 Slope:** Uniform Slope of not less than 1/4" per foot (2%) for 4" diameter, or 1/8" per foot (1%) for 6" diameter. In no case will a slope less than 1/8" per foot (1%) be allowed. [ref: CPC 718.1]

**2.07 Backfill:**

A. **Bedding** [ref: CPC 718.2]:

- (1) **Depth:** 6" minimum depth below bottom of pipe.
- (2) **Material (Typical):** Well graded import, non-plastic, material 100% passing 3/8" sieve (Sand). 90% Compaction.
- (3) **Material (Wet or Yielding Excavations):** 3/4" minus crushed rock
- (4) **Placement:** Placed to allow pipe placement laid on firm, substantially continuous bearing on bottom of trench.

B. **Pipe Zone** [ref: CPC 314.4]:

- (1) **Depth:** 12" minimum depth above top of pipe.
- (2) **Material:** Consistent with Bedding material noted above.

C. **Top Backfill:** Per Owner. No organic matter (roots, etc.), debris, or rocks greater than 3" diameter.

**2.08 Cleanouts:**

A. **Foundation** [ref: CPC 719.1]:

**REQUIREMENTS FOR DESIGN, CONSTRUCTION, AND MAINTENANCE OF CUSTOMER OWNED  
SEWER & WATER SERVICES & APPURTENANCES**

- (1) Christy B09, N09, B12, or G05. (or equivalent brand)
- (2) Install at or within 5' of building footprint.
- (3) Foundation cleanouts shall be a dual-purpose cleanout backwater valve, Mainline Adapt-a-Valve or approved equal.

**B. Mid line [ref: CPC 719.1]:**

- (1) Christy B09, N09, B12, or G05. (or equivalent brand)
- (2) Install at intervals not to exceed 100' in straight runs.

**C. Change in Directions:**

- (1) Christy B09, N09, B12, or G05. (or equivalent brand)
- (2) Install at upstream side at each horizontal change in direction or 45 degrees or greater.

**D. Property line:**

- (1) Christy B09, N09, B12. (or equivalent brand)
- (2) Install immediately inside property line. Property line clean-out shall be a double clean-out.

**2.09 Backwater Valves [ref: CPC 710.1]:** Required installation of a backwater valve at the foundation upon repair or replacement of all or part of the private sewer, upon addition to structures of living quarters and upon installation of additional toilet or drainage facilities in the house. The backwater valve shall be located where readily accessible for inspection and repair. Backwater valves shall be Mainline Straight-Fit, Mainline Adapt-a-Valve or approved equal. Size and location to be approved by the District.

**2.10 Common Trenching (Separation from Water):** 12" horizontal separation. Maintain water 12" minimum above sewer all locations. Water placed on solid shelf excavated at one side of the common trench. [ref: CPC 720.1]

- A. **Common trench means common trench.** If vertical separations cannot be obtained, trench may not simply become wider to obtain the horizontal separation required to hence allow lessening vertical separation requirement. If vertical separations cannot be obtained in common trench, separate trenches are required.

**2.11 Tracer Wire:** Insulated copper direct bury tracer wire with access on/at both ends. Not smaller gauge than 14 AWG

**2.12 Warning Tape:** Green in color, three inches (3") in width, 5 mil in thickness, permanently printed "CAUTION: BURIED SEWER LINE BELOW", installed twelve inches (12") above the pipe.

**2.13 Testing [ref: CPC 712.3]:** Air test per below. Water test may be performed per CPC 712.2 when/if approved by District. The Contractor/Owner shall provide all labor, tools, and equipment necessary to perform required tests. Any faulty equipment shall be replaced before any test is accepted. All test performed under the supervision of Approving Agency.

Test Section shall be from the foundation cleanout to the property line (including property line cleanouts). Any/all sections not passing shall be repaired/corrected and retested as required.

A. **Air:**

- (1) Plug Private Service Lateral at both ends (at foundation cleanout and property line).
- (2) Pressurize lateral to 5 pounds/square inch (psi).
- (3) Pressure shall be held without the introduction of additional air for 15 minutes (min.).
- (4) Test may be repeated once within testing session. A second failed test constitutes failure. No more than one testing session allowed during a single day unless otherwise approved.



REQUIREMENTS FOR DESIGN, CONSTRUCTION, AND MAINTENANCE OF CUSTOMER OWNED  
SEWER & WATER SERVICES & APPURTENANCES

- 2.14** **As-Built Plans:** Owner shall submit As-Built site plan to the District upon completion of work. Site plan shall accurately show service location. PDF format.

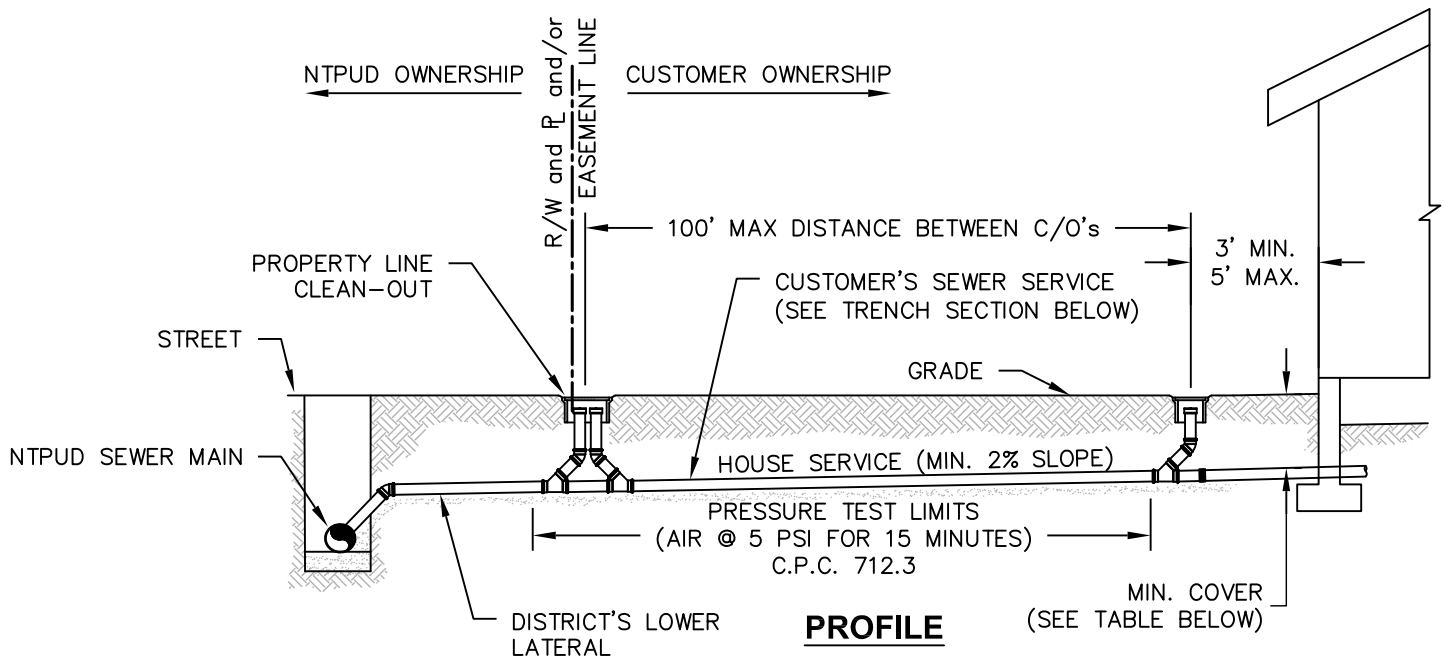

**PROFILE**

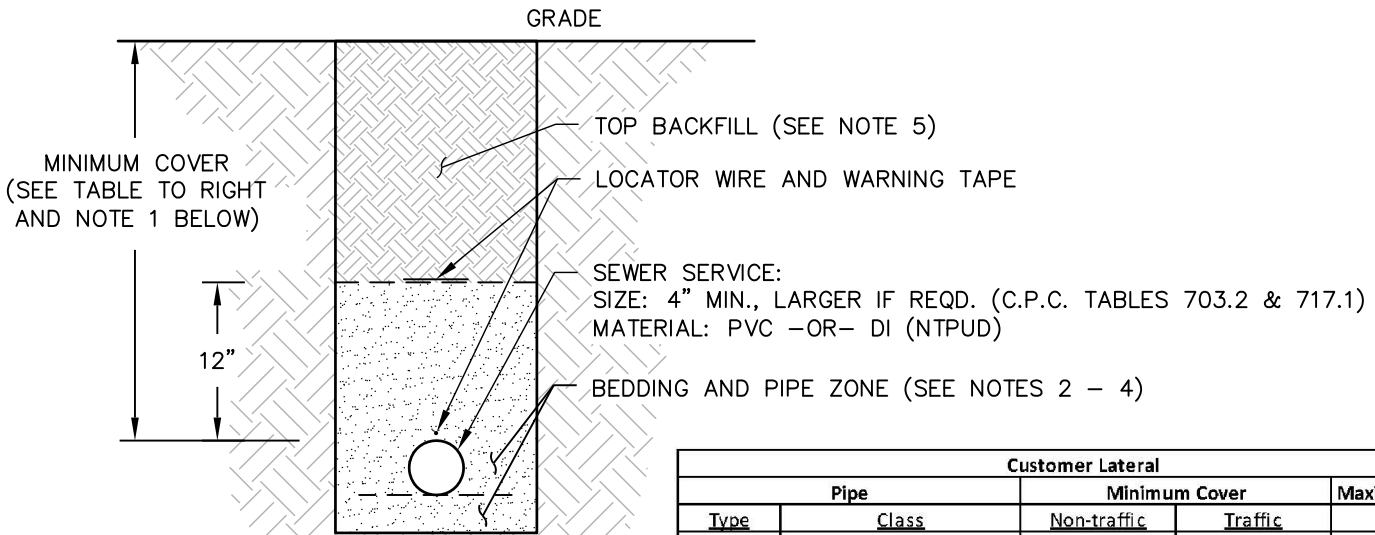

**TRENCH SECTION**

		Customer Lateral		
Pipe		Minimum Cover		Maximum Cover
Type	Class	Non-traffic	Traffic	
PVC	SDR 35	30"	48"	12'
PVC	C900 DR 14	24"	30"	n/a
DI	CL 51 or greater	24"	24"	n/a

**NOTES:**

- COVER SHALL NOT BE LESS THAN LOCAL FROST DEPTH (C.P.C. 312.6)  
(LOCAL FROST DEPTH = 24" PER PLACER CO. FOUNDATION DEPTH REQUIREMENTS (C.R.C. R403.1.4.1 & PLACER COUNTY "FOUNDATION AND SLAB INSPECTION CHECKLIST" (P.C.S.))
- BEDDING (4" BELOW PIPE): WELL GRADED IMPORT, NON-PLASTIC, ALL LESS THAN 3/8" (SAND). PIPE LAID ON FIRM, SUBSTANTIALLY CONTINUOUS BEARING ON BOTTOM OF TRENCH (C.P.C. 718.2)
- PIPEZONE (12" ABOVE PIPE): WELL GRADED IMPORT, NON-PLASTIC, ALL LESS THAN 3/8" (SAND). (C.P.C. 314.4)
- WET OR YIELDING EXCAVATIONS: 3/4" MINUS CRUSHED ROCK MAY BE USED FOR BEDDING AND PIPE ZONE MATERIAL
- TOP BACKFILL: PER OWNER (NO ORGANIC MATTER, DEBRIS, OR ROCK GREATER THAN 3" IN DIAMETER).
- IF REQUIRED, PROVIDE BACKWATER VALVE IN ACCORDANCE WITH C.P.C. 710.1

CALIFORNIA PLUMBING CODE (C.P.C.)  
 CALIFORNIA RESIDENTIAL CODE (C.R.C.)  
 PLACER COUNTY STANDARDS (P.C.S.)  
 NORTH TAHOE PUBLIC UTILITY DISTRICT (NTPUD)



**GRAVITY SEWER SERVICE**  
**FIGURE 2.1**

SCALE: NONE

DATE: 12/12/23



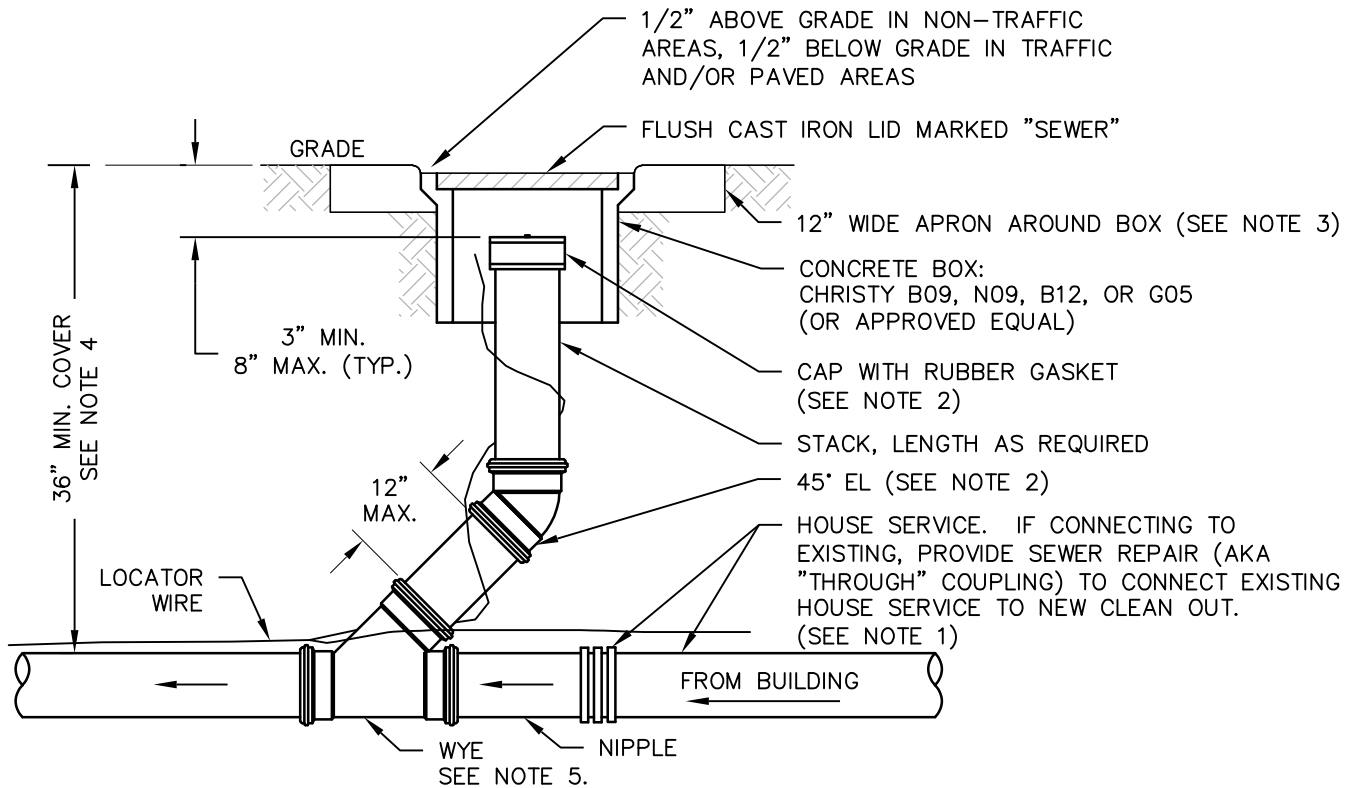

**FOUNDATION, MID-LINE, AND/OR PRESSURE SYSTEM PROPERTY LINE**

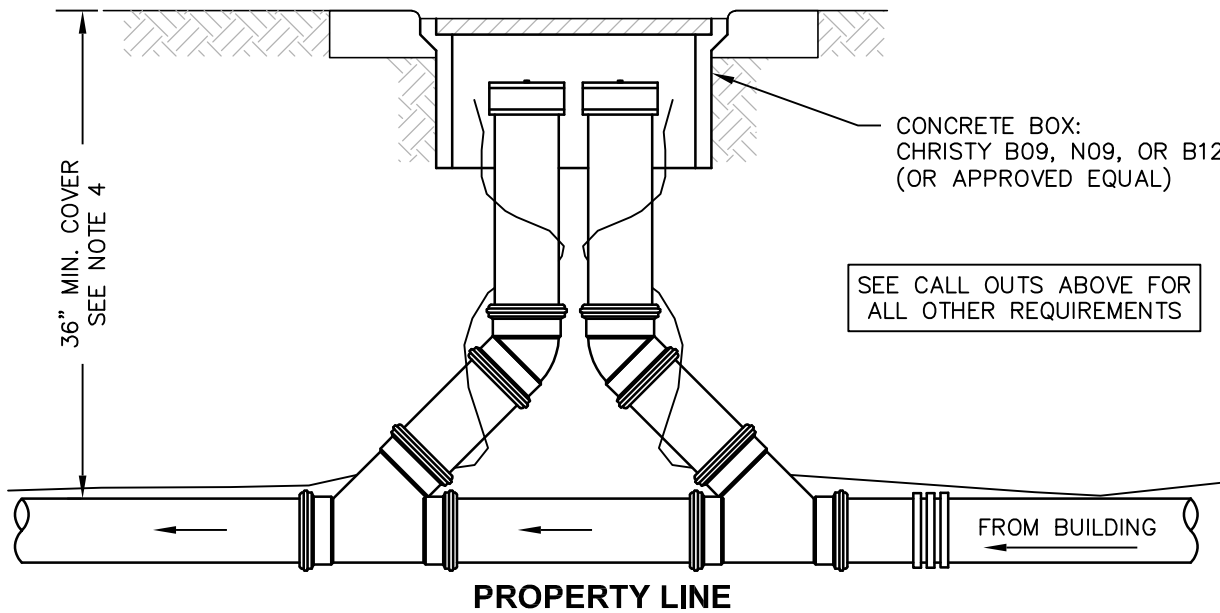

**NOTES:**

1. SEE TECHNICAL SPECIFICATIONS FOR APPROVED MATERIALS.
2. ALL PIPE AND FITTINGS USED IN CLEAN-OUT CONSTRUCTION SHALL BE OF THE SAME MATERIAL AS THAT OF SERVICE LATERAL OR SPECIFICALLY MANUFACTURED FOR APPLICATION.
3. 12" WIDE APRON, (3" THICK ASPHALT (OR MATCH EXISTING) OR 4" THICK CONCRETE) SHALL BE INSTALLED AROUND ALL SIDES OF CLEAN-OUT BOX IN TRAFFIC AND/OR PAVED AREAS.
4. SEE TECHNICAL SPECIFICATIONS FOR PIPE TYPE AND CORRESPONDING COVER REQUIREMENTS.
5. FOUNDATION CLEANOUTS SHALL BE A DUAL-PURPOSE CLEANOUT BACKWATER VALVE.



**SEWER CLEANOUT**  
**FIGURE 2.2**

SCALE: NONE

DATE: 09/13/21



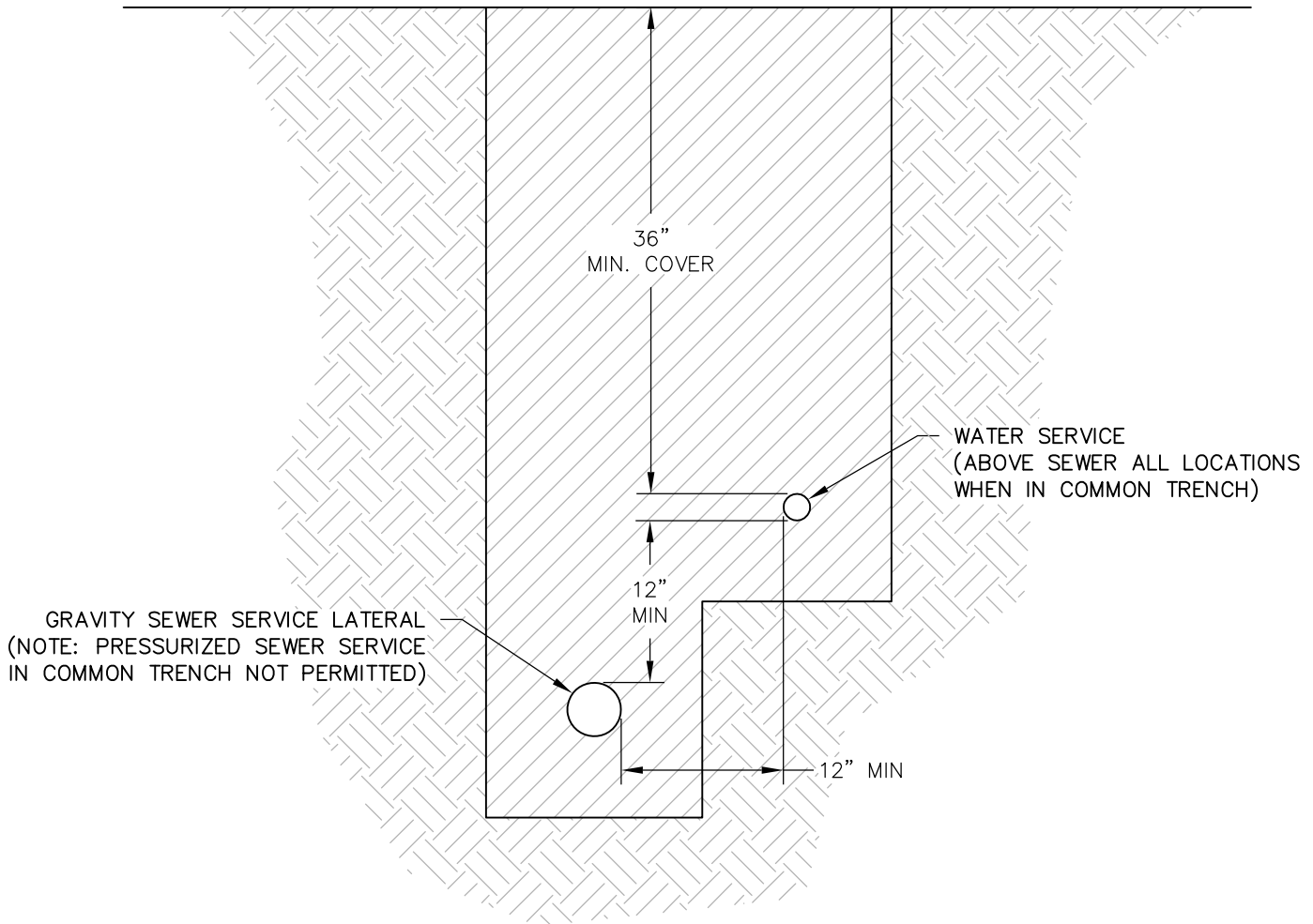

**SEPARATIONS APPLY WHEN COMMON TRENCHED**

**CONSTRUCTION REQUIREMENTS:**

DISTRICT OWNERSHIP LOCATIONS  
(PUBLIC RIGHT-OF-WAY)

CUSTOMER OWNERSHIP LOCATIONS  
(PRIVATE PROPERTY):

SEWER: S-01: LOWER LATERAL  
WATER: W-10: LOWER SERVICE

TECHNICAL SPECIFICATIONS, SECTION 2: GRAVITY SEWER SERVICE  
TECHNICAL SPECIFICATIONS, SECTION 5: DOMESTIC WATER SERVICE

APPLICABLE CODE(S):  
CALIFORNIA PLUMBING CODE: SECTION 609.2 (WATER)  
CALIFORNIA PLUMBING CODE: SECTION 720.1 (SEWER)



**COMMON TRENCH WATER &  
SEWER SERVICE SEPARATION**  
FIGURE 2.3 & FIGURE 5.3

SCALE: NONE      DATE: 06/18/21



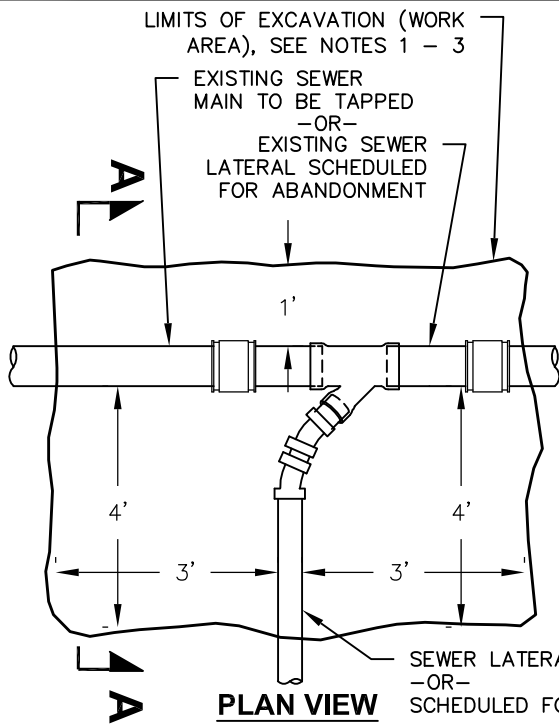

**PLAN VIEW**

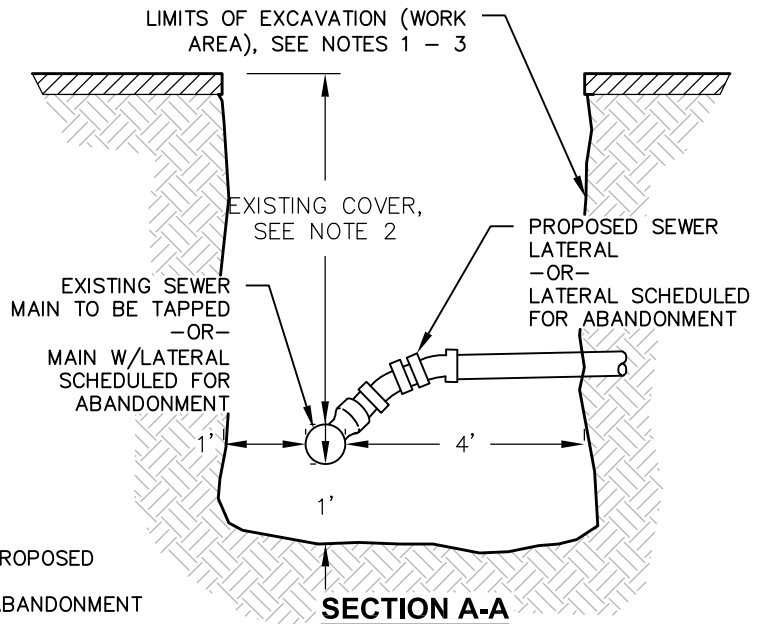

**SECTION A-A**

**SEWER LATERAL TAP or ABANDONMENT**

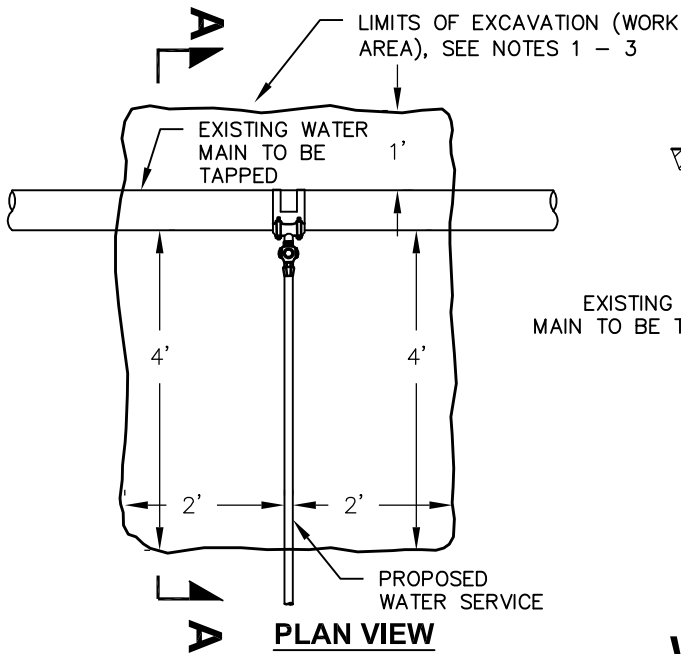

**PLAN VIEW**

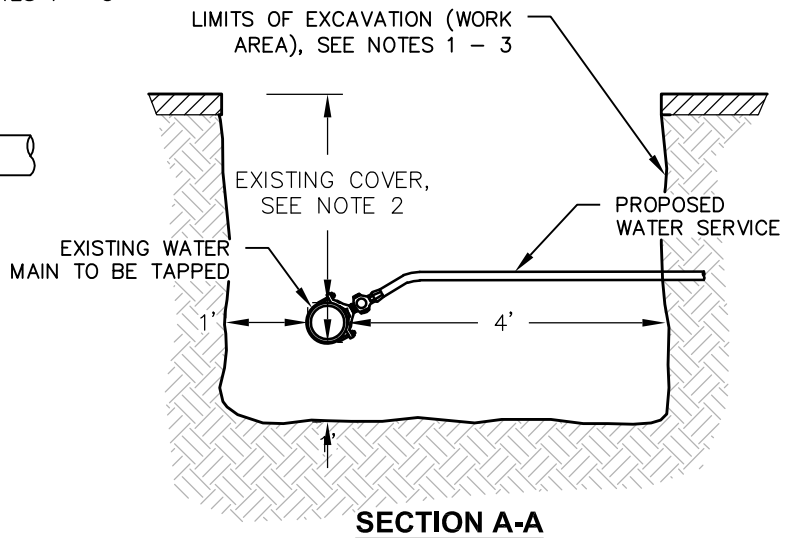

**SECTION A-A**

**WATER SERVICE TAP**

**NOTES:**

1. EXCAVATION SHALL BE FULLY SHORED PER ALL APPLICABLE CAL-OSHA (CALIFORNIA OCCUPATIONAL SAFETY AND HEALTH ADMINISTRATION) REQUIREMENTS.
2. DIMENSIONS SHOWN ARE MINIMAL WORKING SPACE REQUIRED FOR WORK/TOOLS NECESSARY INSIDE SHORING AS APPLICABLE, REGARDLESS OF EXISTING COVER OVER MAIN.
3. DIMENSION SHOWN ARE FOR CONNECTION LOCATION AT MAIN ONLY. SEE TRENCH DETAILS W-20 AND/OR S-20 FOR TRENCH DIMENSIONS REQUIRED FROM CONNECTION LOCATION TO PARCEL LINE.
4. TAP BY NTPUD PERSONNEL WILL NOT BE PERFORMED AND A CALL BACK FEE WILL BE ISSUED TO THE OWNER OF RECORD IF THE ABOVE REQUIREMENTS AND/OR DIMENSIONS ARE NOT FOUND UPON ARRIVAL. SEE NTPUD SEWER AND/OR WATER ORDINANCE ATTACHMENT A-3



**SPACE REQUIREMENTS SEWER / WATER TAPS OR ABANDONMENT**  
**FIGURE 2.4 & FIGURE 5.4**

SCALE: NONE

DATE: 09/13/21



REQUIREMENTS FOR DESIGN, CONSTRUCTION, AND MAINTENANCE OF CUSTOMER OWNED  
SEWER & WATER SERVICES & APPURTENANCES

### 3 WASTE PRETREATMENT REMOVAL DEVICES

**3.01 General:** When and where required per District Ordinance.

- A. **Discharge Limitations:** Pretreatment removal devices shall, at all times, meet discharge regulations per District Sewer Ordinances and as required by Tahoe Truckee Sanitation Agency. [ref: CPC 1009.7]
- B. **Detergents and Agents:** Detergents, chemicals and/or other agents which may temporarily dissolve or emulsify FOG or petroleum-based oils & grease may not be utilized.
- C. **Maintenance:** The Owner shall maintain device(s) as required to maintain working operation and compliance with Discharge Limitations. Maintenance shall include periodic removal and proper disposal of intercepted and accumulated grease and/or other materials. No such collected grease or materials shall be introduced into any sanitary sewer facility. [ref: CPC 1009.6 & CPC 1009.7]
- D. **Record Keeping:** The Owner shall post and maintain a current interceptor cleaning and maintenance log on the premises and shall have the log available for District review at all times and when requested by the District.
- E. **District Inspections:** The District will periodically schedule inspections of premises and interceptors for purposes of ensuring compliance with District Ordinances. Owner shall cooperate and make available any/all request for information as required and applicable.
- F. **District Enforcement:** If the District determines an interceptor is not properly sized/designed, and/or not being properly cleaned or maintained, the district shall have the authority to mandates the installation of a different device, additional equipment or devices, and/or to mandate a maintenance program.

**3.02 Pretreatment Removal Device Types:**

- A. **Food Service Establishments (FSE):** The District has adopted the use of Gravity Grease Interceptors only for fats, oils, and grease (FOG) removal. Other FOG removal devices such as hydromechanical grease interceptors, traps, or other systems shall only be allowed per District variance process.
- B. **Industrial and Other:** The District has adopted the use of Sand-Oil Interceptors for sand and petroleum-based oils and grease removal. Other pretreatment devices shall only be allowed per District variance process.
- C. **Floor Drains:** All floor drains (except those serving showers, public restrooms, laundry, rooms, boiler rooms, and/or walk-in cooler/freezers) shall drain through an approved Pretreatment Removal Device.
- D. **Location:** [ref: CPC 1009.3, CPC 1009.5, & CPC 1014.3.4]
  - (1) Easily accessible for inspection, cleaning, and removal of the intercepted materials (sand, fats, oils, grease (FOG), etc.).
  - (2) As close as practical to the fixtures they serve.
  - (3) Not in a building where food is handled.

**3.03 Gravity Grease Interceptors (FOG)**

- A. **Design & Construction:** FSE/Owner/Applicant shall have a California licensed engineer design the grease control system for the project in accordance with CPC and requirements herein as applicable. Calculations shall be submitted to District for review at time of plan submittal (per 1.07 above). Installation and Construction by California licensed contractor with applicable license.
- B. **Size:** Per CPC Table 1014.3.6.
- C. **Piping/Plumbing:**

**REQUIREMENTS FOR DESIGN, CONSTRUCTION, AND MAINTENANCE OF CUSTOMER OWNED  
SEWER & WATER SERVICES & APPURTENANCES**

- (1) Toilets, urinals, and other similar fixtures shall not drain through the interceptor [ref: CPC 1014.3.2.1]
- (2) Automatic dishwashers may not discharge to interceptor [ref: CPC 1014.1.3]
- (3) Floor Drains located in areas where grease-containing materials exist shall be connected to interceptor [ref: CPC 1014.3.2]

D. **Sample box:** A sample box shall be located at the outlet end and made available for District sampling of effluent quality [ref: CPC 1014.3.5]

**3.04 Sand-Oil Interceptors (Sand and Petroleum-Based Oils and Grease)**

A. **Size, Design & Construction:** Owner/Applicant shall have a California licensed engineer design the effluent control system for the project as required to meet discharge limitations as applicable. Interceptors shall serve a single type of source control. If multiple source conditions are present on single property, multiple interceptors shall be required in accordance with conditions and pre-treatment required. Calculations shall be submitted to District for review at time of plan submittal (per 1.07 above). Installation and Construction by California licensed contractor with applicable license.

B. **Piping/Plumbing:**

- (1) Floor Drains shall be connected to interceptor. Multiple floor drains may discharge to single interceptor, assuming interceptor is serving same purpose and source control. Floor drains shall not be subjected to surface water inflow. [ref: CPC 1011.1 & 1016.1]
- (2) Toilets, urinals, and other similar fixtures shall not drain through the interceptor [ref: CPC 1014.1]

C. **Sample box:** A sample box shall be located at the outlet end and made available for District sampling of effluent quality.

**3.05 Testing:** Water or Vacuum acceptable per below. The Contractor/Owner shall provide all labor, tools, and equipment necessary to perform required tests. Any faulty equipment shall be replaced before any test is accepted. All test performed under the supervision of Approving Agency.

Test applies to interceptor only. All other sections of sewer system tested in accordance with Sewer Service (Gravity) Construction Specifications above. Any/all sections not passing shall be repaired/corrected and retested as required.

A. **Water:**

- (1) Plug inlet and outlet pipes.
- (2) Fill with water, maintain full interceptor for a minimum of 4 hours to allow saturation prior to test.
- (3) Measure water elevation to establish reference, begin test.
- (4) Run test for 4 hours.
- (5) At end of 4 hours, refill & measure water to beginning of test water level.
- (6) If greater than 0.5 gallons are required to fill to beginning test level, interceptor fails.

B. **Vacuum:**

- (1) Plug inlet and outlet pipes.
- (2) Draw vacuum of 4 inches mercury, begin test.
- (3) Measure time for vacuum to drop to 3.5 inches of mercury.
- (4) If less than 120 seconds, interceptor fails.

REQUIREMENTS FOR DESIGN, CONSTRUCTION, AND MAINTENANCE OF CUSTOMER OWNED  
SEWER & WATER SERVICES & APPURTENANCES

## 4 INDIVIDUAL SEWER PUMP STATIONS

- 4.01 General:** When required due to parcel topography and location of District facilities.
- 4.02 Applicable Governing Agency:**
- A. **Placer County, Community Resource and Development Agency:** Applicable to pump systems located within the footprint of building foundation. System shall be approved and inspected in accordance with Placer County Permit. In these cases, the remainder of this section shall not apply.
  - B. **North Tahoe Public Utility District:** Applicable to pump systems located outside the footprint of building foundation. System shall be reviewed, approved, and inspected by District. See below for applicable requirements.
- 4.03 Design and Construction:** Owner shall have a California licensed engineer design the sewer pump system for the property served in accordance with CPC and requirements herein as applicable. Calculations shall be submitted to District for review at time of plan submittal (per 1.07 above). Installation and Construction by California licensed contractor with applicable license.
- 4.04 Maintenance:** Owner shall always maintain system in working order. See holding tank capacity below regarding power outage conditions.
- 4.05 District Inspections:** The District may inspect any individual sewer pump station at any time to determine if it is being properly maintain and/or is in compliance with these specifications. Owner shall cooperate and make available any/all request for information as required and applicable.
- 4.06 District Enforcement:** If the District determines an individual pump station is not properly sized/designed, and/or not being properly cleaned or maintained, the district shall have the authority to mandates the installation of a different system, additional equipment or devices, and/or to mandate a maintenance program.
- 4.07 Location:** Reasonably located to provide for access, inspection, and maintenance
- 4.08 Pump System:** Generally comprised of gravity influent line, holding tank, pump(s), valving/appurtenances, discharge pipe, and alarm/control system. Each addressed below:
- A. **Influent Line:** Per Gravity Sewer Service above
  - B. **Holding Tank:** Water tight. Constructed of concrete, metal, or other approved materials [ref: CPC 10.8]. Adequate holding tank capacity shall be available during power outages as deemed appropriate by designer. Calculations of capacity determination shall be provided at time of plan review submittal.
    - (1) **Cover/Lid:** bolt-and-gasket-type to allow access for inspection, repairs and cleaning. Vent as required to maintain atmospheric pressure (1 ½" min.) [ref: CPC 710.10]
  - C. **Pump(s):** Pump(s) may either be ejector pumps or grinder. Discharge capacity = 20 gpm or greater [ref: CPC 710.3 (1)].
    - (1) **Single Family Residential:** District recommends duplex pump system, though single pump is permitted. Ejector pump(s) shall pass 1 ½" diameter solid ball [ref: CPC 710.3 (2)].
    - (2) **All Other Applications:** Duplex pump system required [ref: CPC 710.9]. Ejector pumps shall pass 2" diameter solid ball [ref: CPC 710.3 (3)].
  - D. **Valving/Appurtenances:** Located where accessible for inspection and repair. Material types and specifications per CPC [ref: CPC 710.4 & 710.6]. Pressure rating equal or greater than discharge pipe.



REQUIREMENTS FOR DESIGN, CONSTRUCTION, AND MAINTENANCE OF CUSTOMER OWNED  
SEWER & WATER SERVICES & APPURTENANCES

- (1) **Ejector Pumps - Single Family Residential:** Backwater or swing check and gate or ball valve downstream of backwater or swing check on pump discharge, 2" min. [ref: CPC 710.3 (2) & 710.4].
- (2) **Ejector Pumps - All Other Applications:** Backwater or swing check and gate or ball valve downstream of backwater or swing check on pump discharge, 3" min. [ref: CPC 710.3 (3) & 710.4]
- (3) **Grinder Pumps – All Applications:** Check valve and fullway-type shutoff valve on pump discharge, 1 ¼" min. [ref: CPC 710.12.1]

E. **Discharge Pipe & Fittings:** Approved pressure rated material as required per pump manufacture and system designer. Sized to maintain minimum velocity = 2 ft/sec. Pressure rating = 200 psi (min.). [ref: CPC 710.4]. Pipe may not be joint trenched with water supply. Maintain 10' (min.) separation.

- (1) **Ejector Pumps – Single Family Residential:** 2" (min.) [ref: CPC 710.3 (2)]
- (2) **Ejector Pumps – All Other Applications:** 3" (min.) [ref: CPC 710.3 (3)]
- (3) **Grinder Pumps – All Applications:** 1 ¼" (min.) [ref: CPC 710.12.1]

**4.09 Alarm/Control System:** Audio and visual alarm, readily accessible, that signals pump failure or an overload condition [ref: CPC 710.9]. Alarms located as such where they are in locations visited daily and can always be seen/heard. In duplex pump systems, pumps shall alternate under normal operations. Pumps shall be enabled to run independent in the event of failure of one pump. Alarm condition shall be enabled in the event of a single pump failure.

**4.10 Construction, Depth, Bedding/Backfill, and Pressure Testing:**

- A. **Discharge Pipe & Fittings – Depth, Bedding/Backfill, and Pressure Testing:** As required per Domestic Water Service above.
- B. **Holding Tank – Pressure Testing:** As required per Waste Pretreatment Removal Devices above.

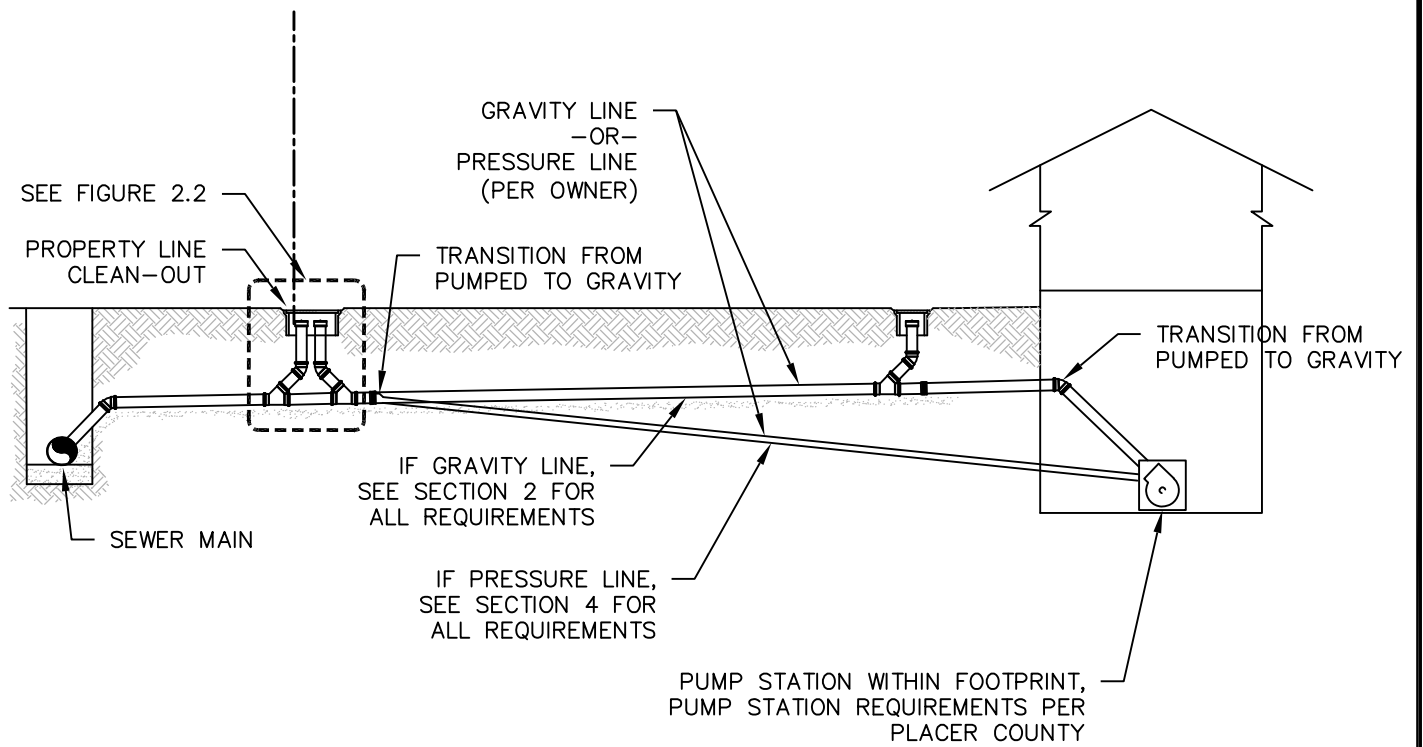

**PUMP STATION WITHIN FOOTPRINT OF BUILDING**

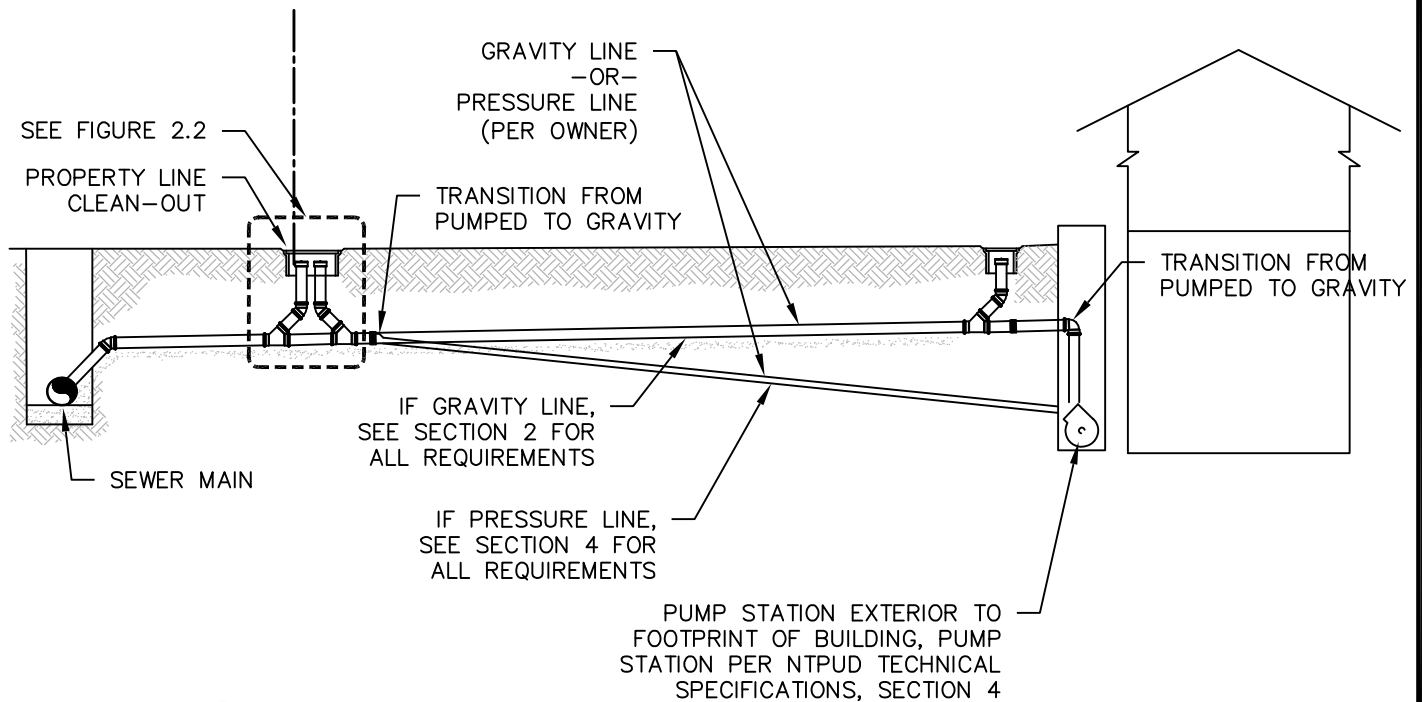

**PUMP STATION EXTERIOR TO FOOTPRINT OF BUILDING**



**TYPES OF PUMPED SEWER**  
**FIGURE 4.1**

SCALE: NONE

DATE: 09/13/21



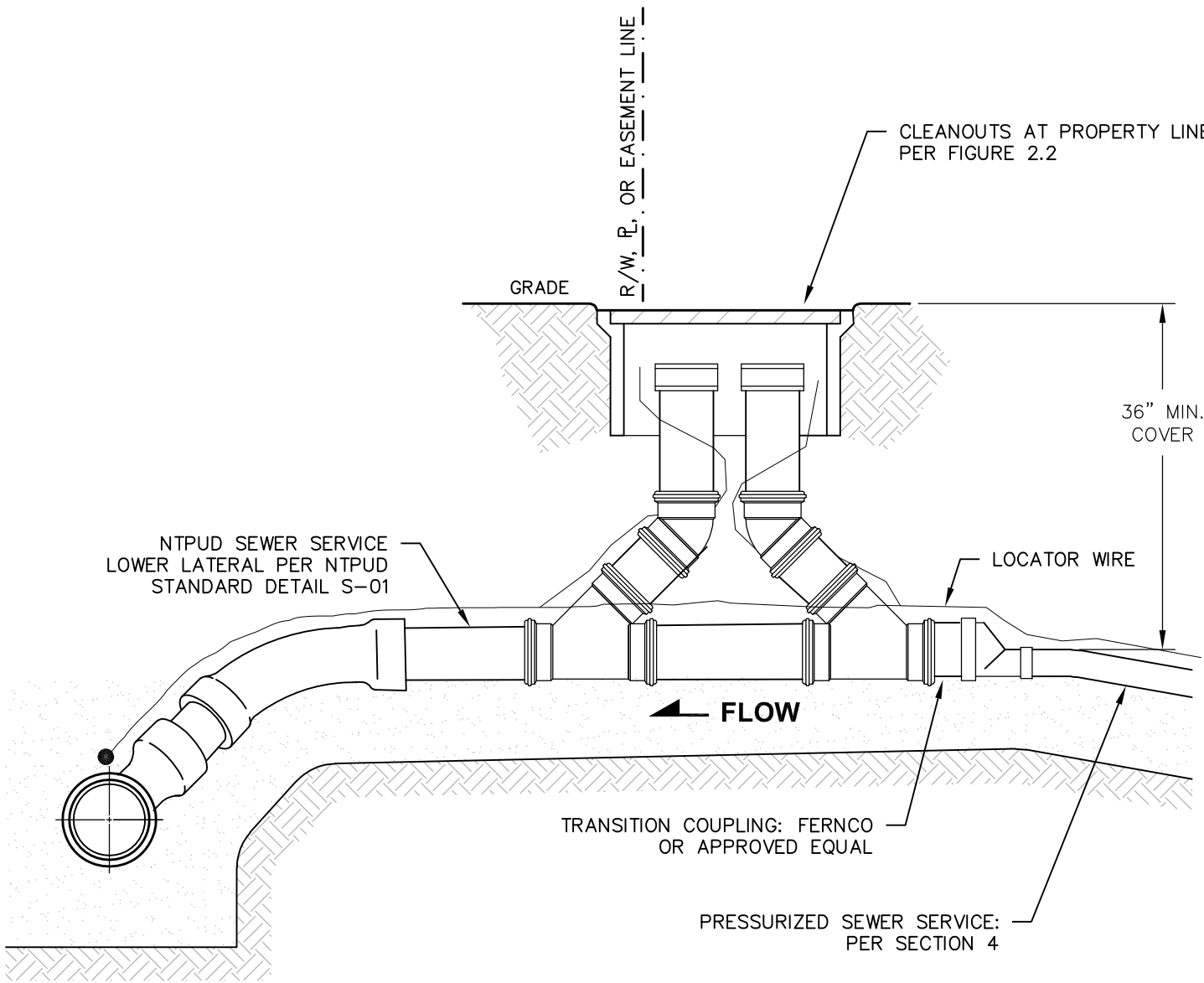

NTPUD SEWER SERVICE  
LOWER LATERAL PER NTPUD  
STANDARD DETAIL S-01

CLEANOUTS AT PROPERTY LINE  
PER FIGURE 2.2

36" MIN.  
COVER

LOCATOR WIRE

FLOW

TRANSITION COUPLING: FERNCO  
OR APPROVED EQUAL

PRESSURIZED SEWER SERVICE:  
PER SECTION 4



**PRESSURIZE SEWER  
SERVICE CONNECTION**  
FIGURE 4.2

SCALE: NONE

DATE: 06/18/21



REQUIREMENTS FOR DESIGN, CONSTRUCTION, AND MAINTENANCE OF CUSTOMER OWNED  
SEWER & WATER SERVICES & APPURTENANCES

## 5 DOMESTIC WATER SERVICE

- 5.01 Customer Service line and Meter Size:** See section 1.10 above.
- 5.02 Location:** Trenches deeper than the footing of a building or structure, and paralleling the same, shall be located not less than 45 degrees from the bottom of the exterior edge of the footing. [ref: CPC 314.1]
- 5.03 Customer Service line (Pipe) Materials:**
- A. **2" and less:**
    - (1) High Density Polyethylene (HDPE), PE 4710, Iron Pipe Size (IPS), SIDR 7 (250 psi). No Joints.
    - (2) Copper, Type K. Conforming to ASTM B-88
  - B. **Greater than 2":**
    - (1) Polyvinyl Chloride (PVC), AWWA C900, Pressure Class 305 psi (DR 14)
    - (2) Ductile Iron Pipe, AWWA C150, Minimum Class 350
- 5.04 Depth:** 36" to top of pipe [ref: CPC 609.1 requiring 12" below local frost depth. note: local frost depth = 24" per Placer Co. foundation depth requirements (ref: CRC R403.1.4.1 and County "Foundation and Slab Inspections Checklist")]
- 5.05 Bedding/Backfill:**
- A. **Bedding:** 6" minimum depth below bottom of pipe. Well graded import, non-plastic, material 100% passing 3/8" sieve (Sand). Placed to allow pipe placement laid on firm, substantially continuous bearing on bottom of trench.
  - B. **Pipe Zone:** 12" minimum depth above top of pipe. Well graded import, non-plastic, material 100% passing 3/8" sieve (Sand). [ref: CPC 314.4]
  - C. **Top Backfill:** Per Owner
- 5.06 Customer Curb Stops:** Required [ref: CPC 606.1]
- A. **Dielectric Unions:** Required when joining dissimilar metals.
  - B. **Valve:** Brass body ball valve (AWWA C800), Wide tee head, Inlet & Outlet Female National Pipe Thread. No stop & drain valves permitted. Acceptable Manufactures: Ford, Mueller, A.Y. McDonald (or approved equal)
  - C. **Riser:** 4" PVC (SDR 35), Cut to length and notched at bottom to match/fit inlet and outlet. Cap with 4" PVC cap fitting with rubber gasket removed.
  - D. **Box & Lid:** Box: Cast Iron. Lid: 5 ¼" Standard, Cast Iron, labeled "WATER". Acceptable Manufacturers: Star Pipe Products VBRENO-W/O-LID, Tyler Pipe (or approved equal)
- 5.07 Common Trenching (Separation from Gravity Sewer):** 12" horizontal separation. Maintain 12" minimum above gravity sewer all locations. Water placed on solid shelf excavated at one side of the common trench. [ref: CPC 609.2]
- A. **Common trench means common trench.** If vertical separations cannot be obtained, trench may not simply become wider to obtain the horizontal separation required to hence allow lessening vertical separation requirement. If vertical separations cannot be obtained in common trench, separate trenches are required.

REQUIREMENTS FOR DESIGN, CONSTRUCTION, AND MAINTENANCE OF CUSTOMER OWNED  
SEWER & WATER SERVICES & APPURTENANCES

- 5.08** **Tracer Wire**: Blue insulated copper direct bury tracer wire with access on/at both ends. Attached to pipe every 5' by means of tape or zip-tie. Not smaller than 14 AWG. Not required for copper services. [ref: CPC 604.10.1]
- 5.09** **Warning Tape**: Blue in color, three inches (3") in width, 5 mil in thickness, permanently printed "CAUTION: BURIED WATER LINE BELOW", installed twelve inches (12") above the pipe.
- 5.10** **Pressure Controls**
- A. **Pressure Regulator**: At all service locations exceeding 60 psi, lead free pressure regulator shall be installed and the static pressure reduced to 60 psi or less. [ref: CPC 608.2 & NTPUD Ord. Chapter 8]
- B. **Location**: Above ground or in a vault sloped to drain with drain daylight. Protected from freezing. [ref: CPC 608.2]
- 5.11** **Pressure Testing**: All test performed under the supervision of Approving Agency.
- A. **All sizes**: Water test at working pressure under which the system is to be used. No leaks for period not less than 15 minutes. Line shall be exposed during duration of test. [ref: CPC 609.4]
- 5.12** **Disinfection**: As Required per Placer County Community Development Resource Agency – Building Division [ref: CPC 609.9]
- 5.13** **As-Built Plans**: Owner shall submit As-Built site plan to the District upon completion of work. Site plan shall accurately show service location. PDF format.

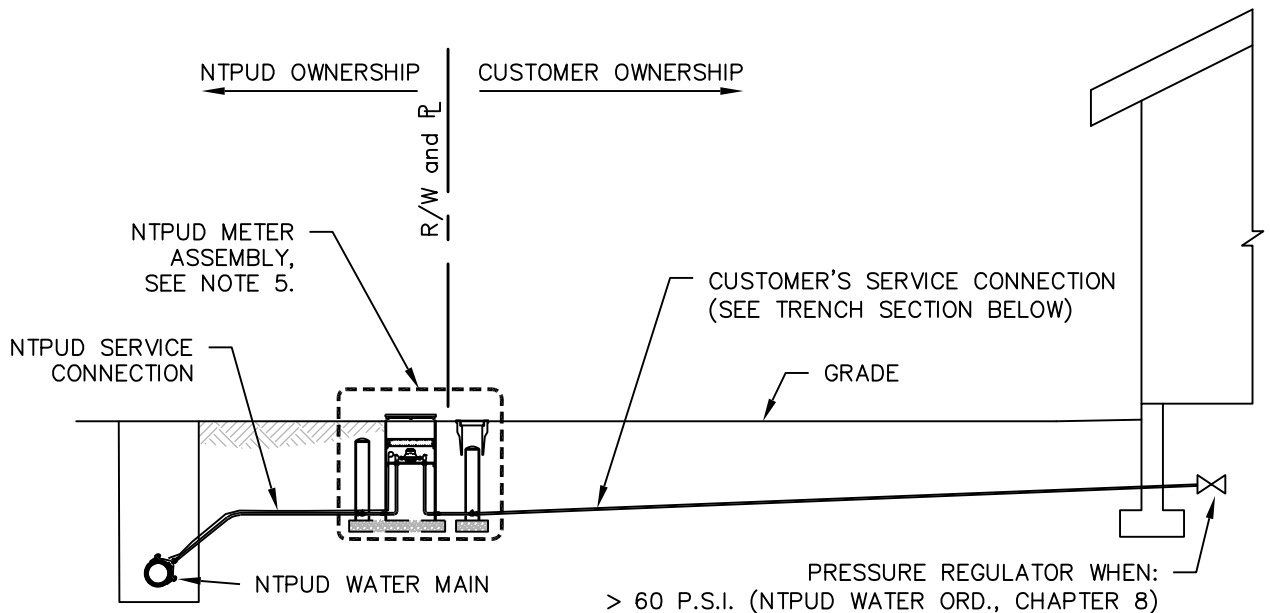

**PROFILE**

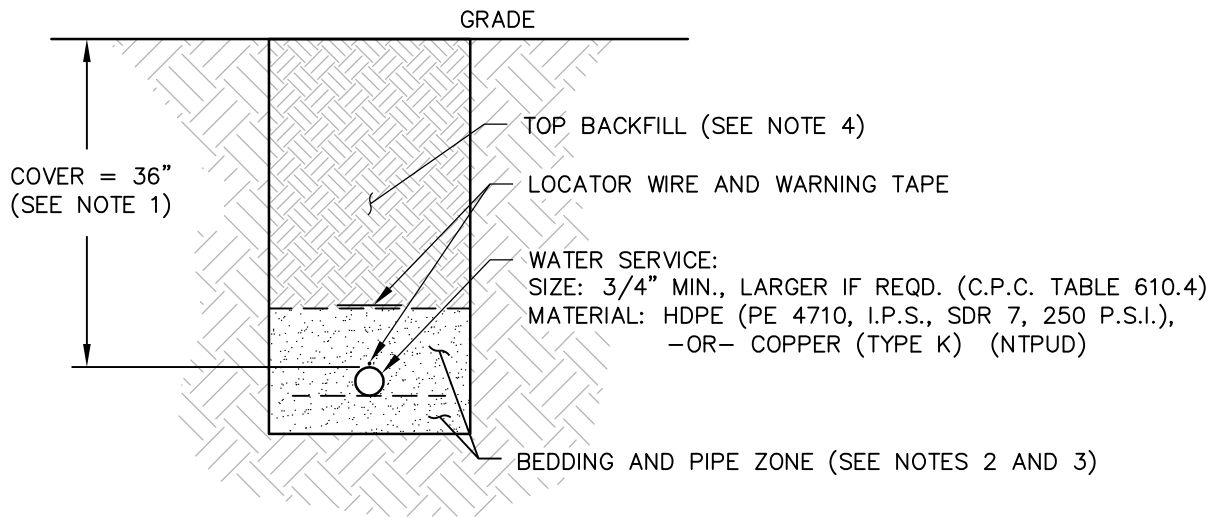

**TRENCH SECTION**

**NOTES:**

1. COVER SHALL NOT BE LESS THAN 12" BELOW LOCAL FROST DEPTH (C.P.C. 609.1)  
(LOCAL FROST DEPTH = 24" PER PLACER CO. FOUNDATION DEPTH REQUIREMENTS (C.R.C. R403.1.4.1 & PLACER COUNTY "FOUNDATION AND SLAB INSPECTION CHECKLIST" (P.C.S.))
2. BEDDING (6" BELOW PIPE): WELL GRADED IMPORT, NON-PLASTIC, ALL LESS THAN 3/8" (SAND). PIPE LAID ON FIRM, SUBSTANTIALLY CONTINUOUS BEARING ON BOTTOM OF TRENCH (C.P.C. 609.2)
3. PIPEZONE (12" ABOVE PIPE): WELL GRADED IMPORT, NON-PLASTIC, ALL LESS THAN 3/8" (SAND). (C.P.C. 314.4)
4. TOP BACKFILL: PER OWNER.
5. PROVIDE METER ASSEMBLY PER NTPUD STANDARD DETAILS. REFER TO W-01, W-02, W-03, W-04, AND W-05.

APPLICABLE CODE(S):  
 CALIFORNIA PLUMBING CODE (C.P.C.)  
 CALIFORNIA RESIDENTIAL CODE (C.R.C.)  
 PLACER COUNTY STANDARDS (P.C.S.)  
 NORTH TAHOE PUBLIC UTILITY DISTRICT (NTPUD)



**DOMESTIC WATER SERVICE**  
**FIGURE 5.1**



SCALE: NONE

09/13/2021

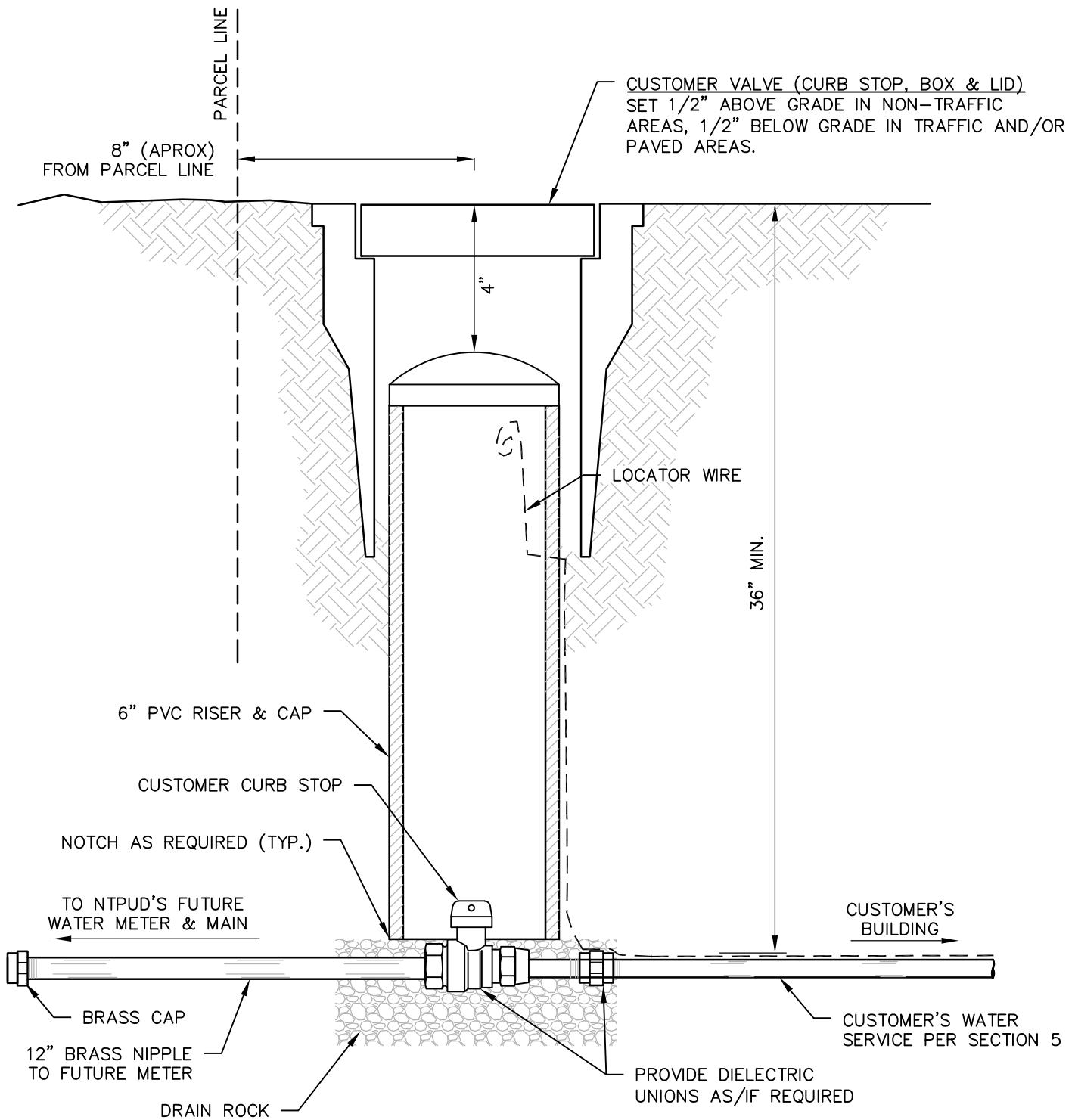

**DETAIL NOTES:**

1. FUTURE HOUSE SERVICES ARE INSTALLED AT THE CUSTOMERS DISCRETION.
2. VISUAL INSPECTION BY DISTRICT PERSONAL REQUIRED PRIOR TO BURIAL.
3. SIZE OF VALVE (CURB STOP) SHALL BE CONSISTENT WITH SIZE OF WATER SERVICE LINE REQUIRED TO SERVE PROPERTY.
4. SEE NTPUD TECHNICAL SPECIFICATIONS SECTION 5 FOR REQUIREMENTS.



**FUTURE HOUSE SERVICE  
FIGURE 5.2**

SCALE: NONE

DATE: 06/18/21



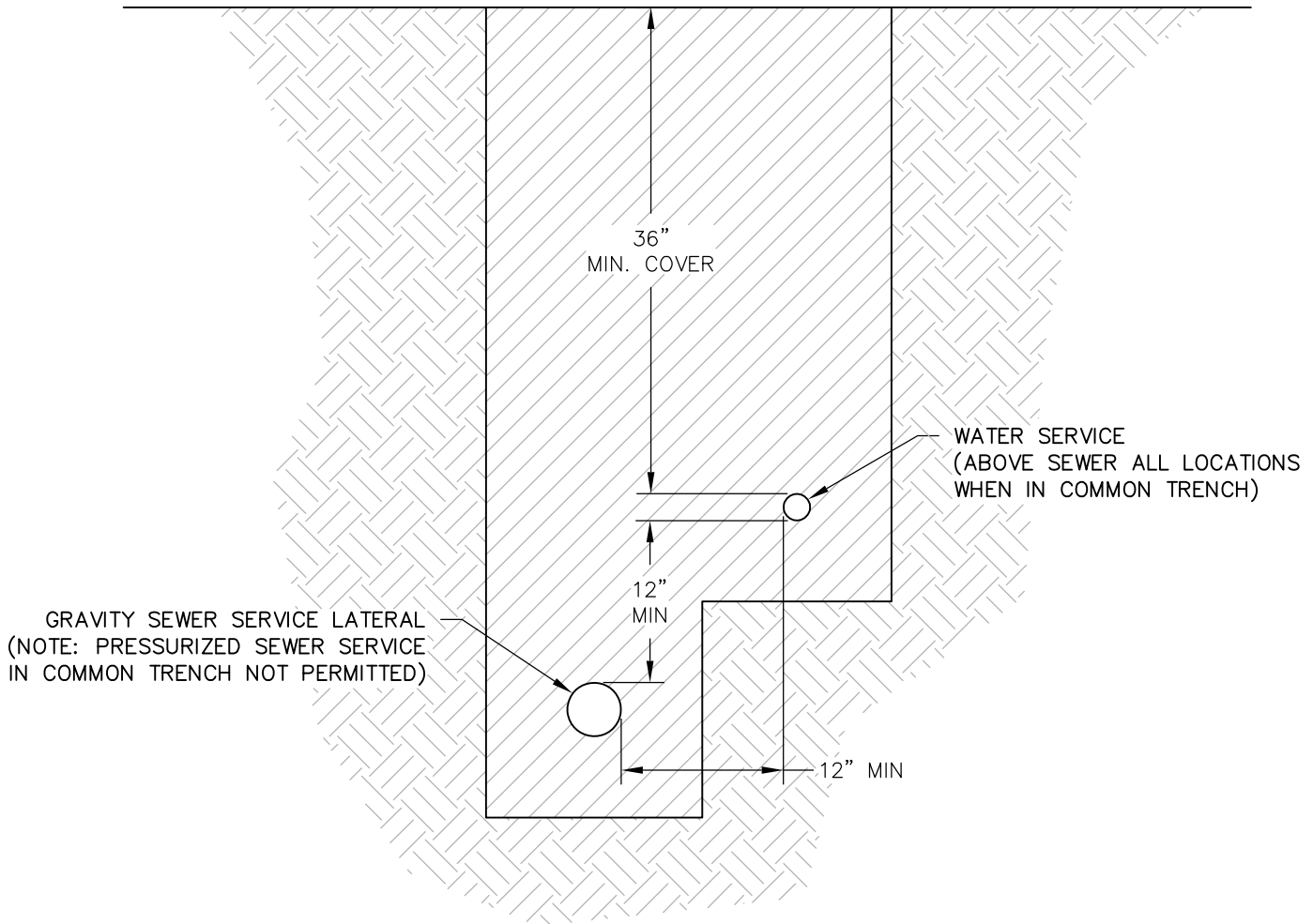

**SEPARATIONS APPLY WHEN COMMON TRENCHED**

**CONSTRUCTION REQUIREMENTS:**

DISTRICT OWNERSHIP LOCATIONS  
(PUBLIC RIGHT-OF-WAY)

CUSTOMER OWNERSHIP LOCATIONS  
(PRIVATE PROPERTY):

SEWER: S-01: LOWER LATERAL  
WATER: W-10: LOWER SERVICE

TECHNICAL SPECIFICATIONS, SECTION 2: GRAVITY SEWER SERVICE  
TECHNICAL SPECIFICATIONS, SECTION 5: DOMESTIC WATER SERVICE

APPLICABLE CODE(S):  
CALIFORNIA PLUMBING CODE: SECTION 609.2 (WATER)  
CALIFORNIA PLUMBING CODE: SECTION 720.1 (SEWER)



**COMMON TRENCH WATER & SEWER SERVICE SEPARATION**  
FIGURE 2.3 & FIGURE 5.3  
SCALE: NONE      DATE: 06/18/21





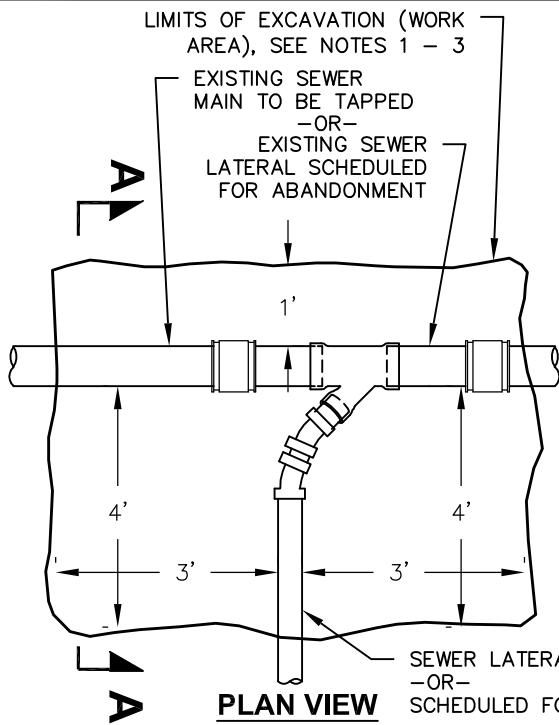

**PLAN VIEW**

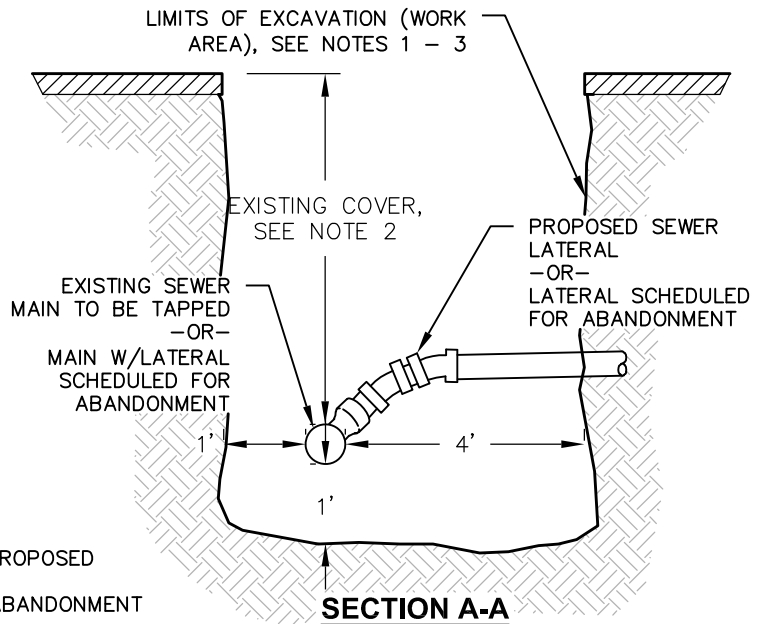

**SECTION A-A**

**SEWER LATERAL TAP or ABANDONMENT**

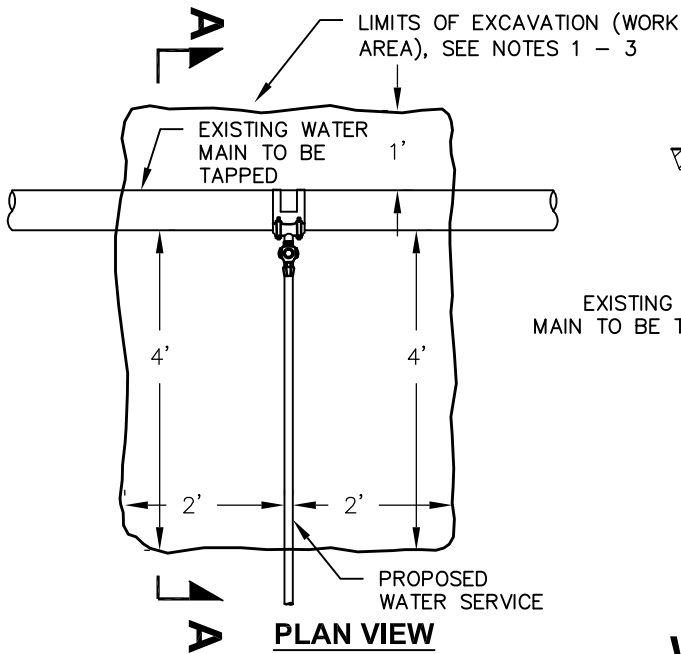

**PLAN VIEW**

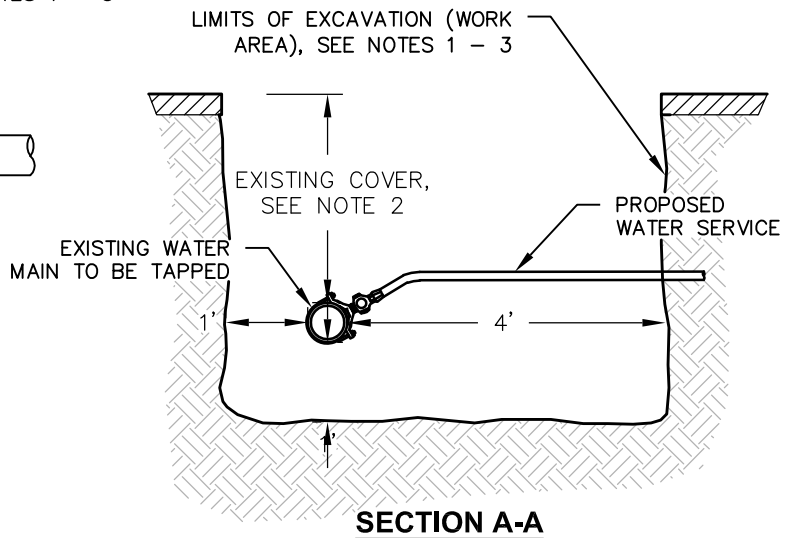

**SECTION A-A**

**WATER SERVICE TAP**

**NOTES:**

1. EXCAVATION SHALL BE FULLY SHORED PER ALL APPLICABLE CAL-OSHA (CALIFORNIA OCCUPATIONAL SAFETY AND HEALTH ADMINISTRATION) REQUIREMENTS.
2. DIMENSIONS SHOWN ARE MINIMAL WORKING SPACE REQUIRED FOR WORK/TOOLS NECESSARY INSIDE SHORING AS APPLICABLE, REGARDLESS OF EXISTING COVER OVER MAIN.
3. DIMENSION SHOWN ARE FOR CONNECTION LOCATION AT MAIN ONLY. SEE TRENCH DETAILS W-20 AND/OR S-20 FOR TRENCH DIMENSIONS REQUIRED FROM CONNECTION LOCATION TO PARCEL LINE.
4. TAP BY NTPUD PERSONNEL WILL NOT BE PERFORMED AND A CALL BACK FEE WILL BE ISSUED TO THE OWNER OF RECORD IF THE ABOVE REQUIREMENTS AND/OR DIMENSIONS ARE NOT FOUND UPON ARRIVAL. SEE NTPUD SEWER AND/OR WATER ORDINANCE ATTACHMENT A-3



**SPACE REQUIREMENTS SEWER / WATER TAPS OR ABANDONMENT**  
**FIGURE 2.4 & FIGURE 5.4**

SCALE: NONE

DATE: 09/13/21



REQUIREMENTS FOR DESIGN, CONSTRUCTION, AND MAINTENANCE OF CUSTOMER OWNED  
SEWER & WATER SERVICES & APPURTENANCES

## 6 FIRE SERVICE

- 6.01 Requirement:** As determined by Placer County and/or North Tahoe Fire Protection District.
- 6.02 District Owned Service Line:** Per paragraph 1.14 above, District owned water service to parcel shall consist of a single service line. Per paragraph 1.09, connection fees shall be based on individual uses proposed and their respective size(s).
- A. **New fire service on parcel without any existing service:** Single line to serve all proposed uses/demands on parcel as anticipated at time of installation.
- B. **New fire service on parcel with an existing water service:**
- (1) If existing service is adequately sized to serve existing use and proposed fire use, fire connection may be made immediately ahead of existing water meter.
  - (2) If existing service is not adequately sized to serve existing use and proposed fire use, new District owned single service line shall be installed at adequate size to serve all proposed uses/demands on parcel.
- 6.03 Size & Design:** System shall be designed and sized by certified and qualified fire protection engineer.
- 6.04 District Plan Review Process:**
- A. Single Family Residential: Fire sprinkler plans are not required at time of application. Process per below:
- (1) Dedicated fire connection size initially assumed as 1" for establishment of fees and determination of available flow.
  - (2) District will provide available flow and pressure at property line service connection, and static pressure at main upon request.
  - (3) Customer to design system and verify adequacy of District supply.
  - (4) If available flow and assumed 1" size is found not adequate, customer shall contact District to establish required size.
- B. All other customer classes: Fire sprinkler plans are required at time of application. District's review and approval consists only to establish service size (and associated fee requirements) and ensure adequate backflow prevention.
- 6.05 Fire Service Line (Pipe) Construction:** Materials, Depth, Backfill, Separation from Sewer, Tracer Wire, Pressure Testing, and As-Built Plans as required per Domestic Water Service specifications above.
- 6.06 Backflow Prevention:** Required per Section 7.

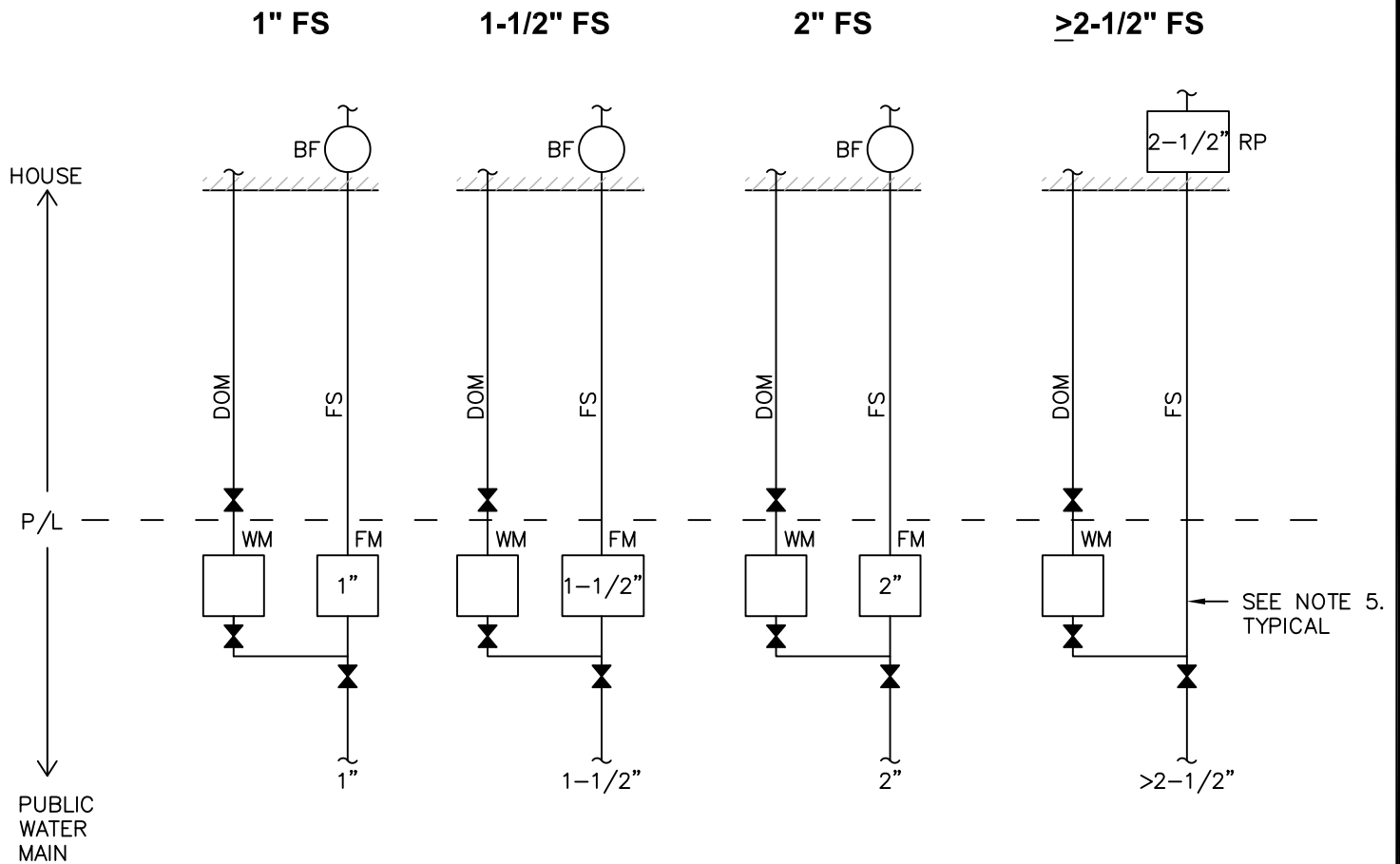

**LEGEND:**

- DOM = DOMESTIC WATER
- FS = FIRE SERVICE
- WM = WATER METER (SIZED AS REQUIRED BY NTPUD)
- BF = BACKFLOW ASSEMBLY (SEE NOTE 1)
- FM = FIRE METER (SEE NOTE 2)
- RP = REDUCED PRESSURE PRINCIPLE ASSEMBLY (SEE NOTE 1)
- P/L = PROPERTY LINE
- ☒ = VALVE

**NOTES:**

1. BACKFLOW ASSEMBLY SUPPLIED BY CUSTOMER. LOCATE INSIDE A BUILDING OR AN INSULATED AND HEATED UTILITY BOX. MUST BE AIRGAP OR REDUCED PRESSURE PRINCIPLE ASSEMBLY. MATERIAL AND MANNER OF CONSTRUCTION PER TECHNICAL SPECIFICATIONS, SECTION 7.
2. NTPUD WILL SUPPLY FIRE METER ASSEMBLY.
3. LAYOUTS ASSUME SINGLE CUSTOMER FOR EACH SERVICE LATERAL.
4. SEPARATION, CONSTRUCTION AND INSPECTION PER CALIFORNIA PLUMBING CODE AND FIRE CODE.
5. NO CURB STOPS OR VALVES ALLOWED ON FIRE SERVICE LINE.



**FIRE SYSTEM REQUIREMENTS**  
FIGURE 6.1

SCALE: NONE

DATE: 7/9/21



**REQUIREMENTS FOR DESIGN, CONSTRUCTION, AND MAINTENANCE OF CUSTOMER OWNED  
SEWER & WATER SERVICES & APPURTENANCES**

**7 BACKFLOW AND CROSS-CONNECTION CONTROL**

**7.01 When, Where, and Type of Protection Required:** Backflow protection shall be required according to the degree of potential health hazard to the public water supply which may be created as a result of conditions existing on a user’s premises. The type of protection required shall be in accordance with Table below, listed in an increasing level of protection. The water user may choose a higher level of protection than that required. Situations not covered in below Table shall be evaluated on a case-by-case basis with the appropriate type of backflow protection determined by the District. The District reserves the right to require a more stringent device than that listed if, in its sole judgement, the circumstances of that water user requires a higher degree of protection.

**Abbreviations:**

- BPD: Backflow Protection Device
- AVB: Atmospheric Vacuum Breaker
- PVB: Pressure Vacuum Breaker
- DC: Double Check Valve Assembly
- RP: Reduced Pressure Principle Assembly
- AG: Air Gap Separation

Hazard Criteria and Required Type of Backflow	BPD Allowed					Device Location	
	AVB	PVB	DC	RP	AG	Fixture Protection	Service Protection
						In-premise Protection	Premises Isolation
<b>Fire Protection System - all types</b>				√	√		√
<b>Boiler &amp; Hydronic Systems:</b>							
• Connected to potable water system for make up water				√	√	√	
• Closed loop system not connected. Requires reservoir for make up water, double-walled heat exchanger, and approval by District inspector. (*occurs by default with reservoir)					√*	√	
<b>Marinas</b>				√			√
<b>Irrigation Systems:</b>							
• Dedicated Irrigation Service		√**		√	√		√
• Into which fertilizers, herbicides, or pesticides are, or can be, injected or subject to back pressure				√	√	√	√
<b>Premises:</b>							
• Where substances harmful to health are handled under pressure and/or in any manner in which the substances may enter to potable water system. Includes water from public water supplies which have deteriorated in sanitary quality.				√**	√		√
• Where there is waste water pumping and there is no interconnection with the potable water system (does not include single-family residence with a sewage lift pump)				√**	√		√
• Where there is an auxiliary water supply				√**	√		√
• That have internal cross-connection that are not abated, or cannot be permanently corrected or controlled, to the satisfaction of the District.				√	√		√
• With intricate plumbing or piping arrangements				√	√		√
• Where cross-connections are likely to occur.				√	√		√
• Where entry is restricted so that cross-connection inspections cannot be made with sufficient frequency or at sufficiently short notice to assure that cross-connections do not exist.				√	√		√
• Having a repeated history of cross-connections being made.				√	√		√
							** Upon approval only

**7.02 Approved Devices:** Approved backflow prevention devices are those listed in University of Southern California – List of Approved Backflow Prevention Assemblies (latest edition) and in accordance with correct application. List available at <https://fccchr.usc.edu/list.html> or upon request.

**7.03 Installation and Location:** Devices shall be installed according to manufactures recommendations, in accordance with application, and in a configuration, orientation, and location as approved by the District.